

# HOTBOX SE

for firmware version 1.03 or higher; Hotseries 4 Protocol

## 1. Product Description

The HOTBOX SE is a universal datalogger designed for logging 4 autonomous physical values. It can be implemented together with a large selection of external sensors and in combination with ECOLOG dataloggers, thus providing the optimal solution for a diversity of possible applications.

The HOTBOX SE offers users 2 voltage, 2 current and 2 NTC temperature measuring channels. Any combination of 4 channels can be selected from the available 6 measuring channels.

For example: flow rate in an air duct as voltage signal, CO<sub>2</sub> concentration in exhaust air as 4-20mA current signal and the temperature of inlet and exhaust air with both NTC temperature channels.

Various job-specific, adjustable power-save modes make it possible to achieve a high degree of autonomy for recording measuring signals. The used probes can be supplied with energy by internal batteries (18V) or by an external source.

The software for programming the datalogger and for statistical evaluation of measured data can be used for all other dataloggers manufactured by ELPRO-BUCHS AG.

HOTBOX SE dataloggers require evaluation software elproLOG version 3.31 or higher. Refer to the elproLOG CD-ROM for further information

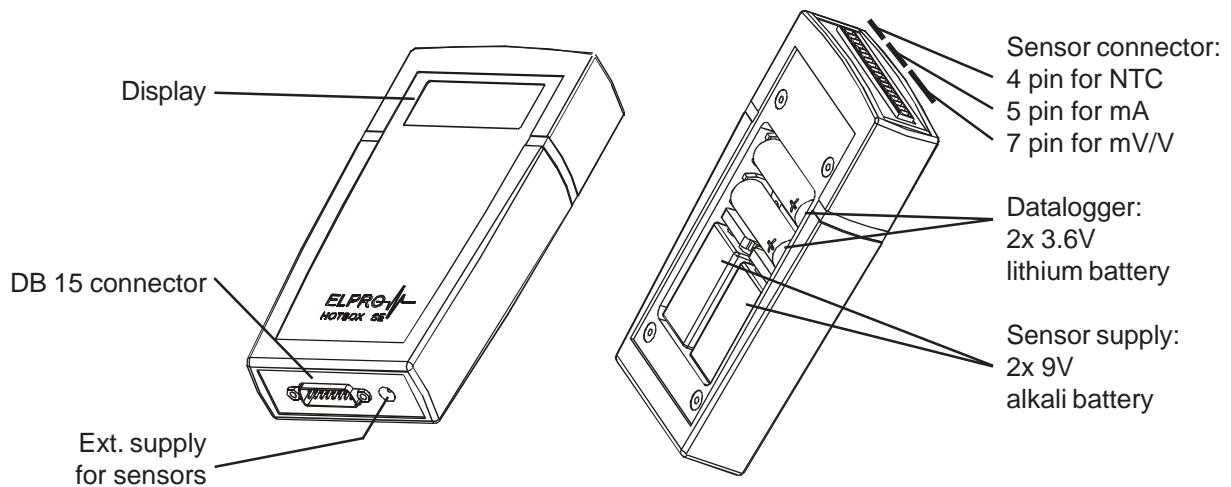

Fig. 1

### Assignment of measuring channels on the display

Channel

S1	1st temperature with NTC probe	4 pin connector
S2	2nd temperature with NTC probe	4 pin connector
S3	1st sensor signal in 0/4 - 20mA	5 pin connector
S4	2nd sensor signal in 0/4 - 20mA	5 pin connector
S5	1st sensor signal in mV/ V	7 pin connector
S6	2nd sensor signal in mV/V	7 pin connector

## 2. Display and Functions

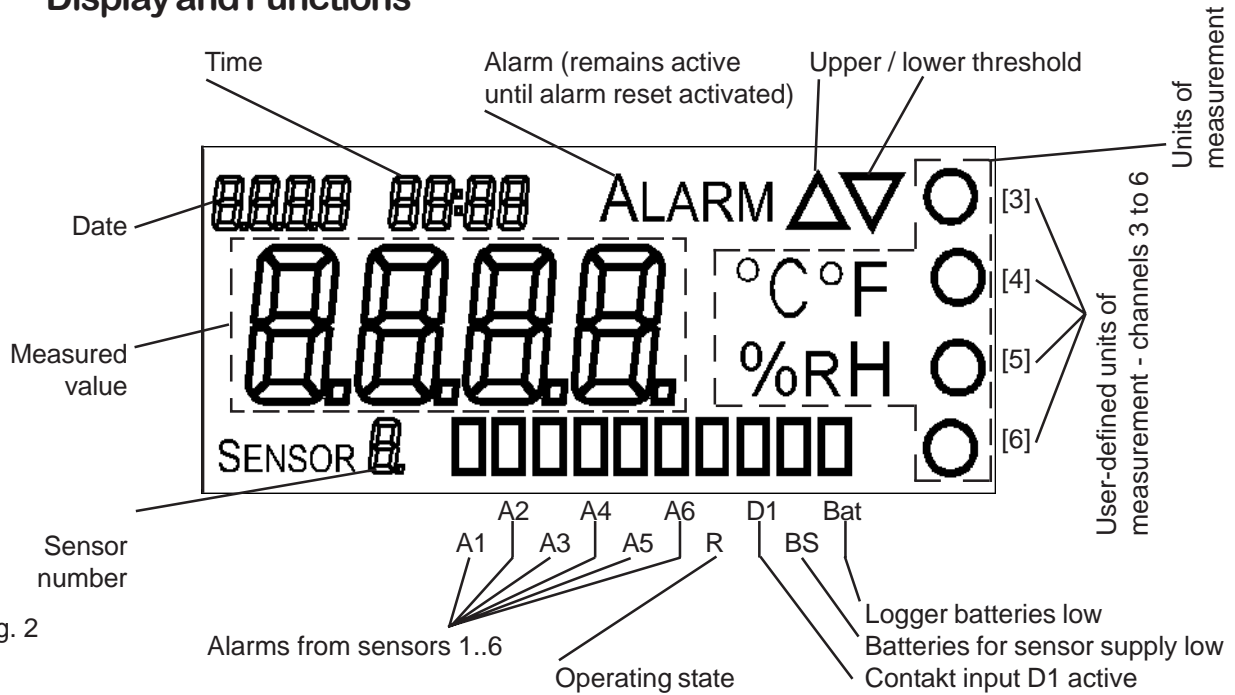

Fig. 2

### Units of measurement

°C, °F and %rH are shown directly on the display.

For tests, it is possible to show sensor signals directly on the display in mV / V or mA.

### User-defined units of measurement

Can be mounted at the respective channel with user-labeled clip (Part.-No 2540-CL).

### Alarms from sensors 1..6

Indicators are active at the particular sensor which triggered the alarm.

They are only active for the duration of an alarm.

### Operating state

The operating state indicator (R) or the display allows you to differentiate between the various datalogger operating states. The power save mode (activated/deactivated) influences the indication of the operating state in the display. (see Chapter 2.2).

The 3 states of indicator (R) are:

- On** The datalogger runs in Loop mode or Start/Stop mode and stores measured values in accordance with the settings made in Setup.
- Blinking** The datalogger waits in External Start/Stop mode for start activation from digital input D1 or in Start/Stop mode till start time has been reached.
- Off** The state is reached when the datalogger is in Start/Stop mode and the logger memory capacity is full.

### Battery status BS and Bat

Refer to chapter 3 for further information about these indicators.

## 2.1 Contact inputs D1 and D2

An inquiry at contact inputs D1 and D2 is only prompted when a measurement is made. This means that the datalogger does not register a status change which occurs between two measurements until the second measurement is made.

For example, a status change such as Off-On-Off which occurs between two measurements will not be registered!

Only the state of contact input D1 is shown as flag on the display. When a contact input is activated, it is shown briefly in the measured value display (dI, d2).

Both contact inputs (D1 and D2) are assigned dual functions:

FUNCTION	DATALOGGER STATUS			
	Wait until start	Recording in progress	Alarm function active	Alarm registered
External Start	D1; 5 Pin Conn.			
Alarm-Delay			D1; 5 Pin Conn.	
Marking#		D2; DB15 Conn.		
Alarm Reset				D2; DB15 Conn.

# The status of D2 is only shown in the table of measured values. It is not displayed in the graphics!

## 2.2 Power-save Mode

The HOTBOX SE has a power-save mode, which switches off the display. As a result, measurements are only made during the defined log interval. 4 small circles located in the display for the measured values indicate that the datalogger is still functioning correctly. during the recording process.

The elproLOG Software - Extended Setup - Display mode / Powersave is responsible for switching this mode on and off.

If you need to make a check, you can use the DispOn connector to switch the display on temporarily.

STATUS	DISPLAY REPRESENTATION		
	Power-save Mode „Off“	Power-save Mode „On“	Operating state (R)
Wait until start or external start	<b>St r t</b>	no Display	Blinking
Recording in progress	actual measurement value	<b>0000</b>	On
Stop	<b>St OP</b>	<b>0000</b>	Off

## 2.3 Recording of measured values



Recording of measured values always begins immediately after one of the following actions.

The selected sensor supply configuration has no influence:

- Reprogramming of the loggers in loop mode
- Start of measurement activated by time setting or start connector
- Display switched on by DispOn connector or by elproLOG software

This can result in the following: incorrect measured values can be displayed and saved; false alarms can be triggered. This is caused by the fact that the sensor supply time has not elapsed when the first measurement is made and the sensor therefore transmits an invalid measurement result.

### 3. Batteries and Serviceable Life

#### 3.1 Battery Display

The datalogger is fitted with 2 status displays for internal batteries:

**BS** When this indicator appears, both 9 Volt, 0.4Ah, 6LR61 batteries, responsible for sensor energy supply, should be replaced.



This indicator is adjusted to register the performance of 9 Volt alkali batteries. Inaccurate information can be displayed if accumulator or other batteries are used. These batteries can simply be removed from the logger during non-working periods.

**Bat** When this indicator appears, both 3.6 Volt 1900mAh, AM3/LR6/AA lithium batteries, responsible for logger energy supply, should be replaced.



An energy consumption count monitors the life-span of the logger batteries. For this reason, only the specific batteries recommended by the manufacturer should be used in the logger. Do not remove the batteries from the logger during non-working periods. The use of other batteries or the removal of batteries will produce incorrect status information at the battery indicator.

**You must reset the battery change time (elproLOG Software - Extended Setup - Programming of battery changetime...) after you replace batteries otherwise the energy counter will not function correctly!**

#### 3.2 Serviceable Life

The serviceable life of the HOTBOX SE is influenced by various factors such as:

- Sensor type (I, U, NTC)
- Power consumption of sensors when supplied by internal batteries
- Sensor supply time
- Log interval
- Frequency and amount of data read-out

#### 3.3 Precautionary Measures for Handling Units with Lithium Batteries

- Do not short-circuit batteries: Danger of explosions
- Do not throw units which contain batteries into fire: Danger of explosions
- Do not subject the batteries to mechanical stress and do not dismantle them. The leaking battery fluid is highly corrosive and lithium can generate severe heat when it comes into contact with moisture or it can ignite fire.
- Do not heat up battery-driven units to temperatures exceeding 100°C: Danger of explosions
- Avoid violent knocks and blows
- Follow the manufacturer's specifications for battery storage
- Return the batteries to the supplier for correct waste disposal

## 4. Applications and Safety Regulations

### 4.1 elproLOG Version 3.31 or higher

- The firmware release 1.03 contains a faster communication protocol. For communication the following settings in the elproLOG software should be made:  
Options - ComPort - RS232 & 57600 (Hotseries 4) & appropriate COM-Port.
- By using the function: Use logger alarm limits as min/max limits in the elproLOG software, the first pair of limit values (min/max) per y axis is represented in each case only.
- The overlay function in version 3.31 supports up to 4 different measured variables and up to 16 measuring curves per graphics.

### 4.2 Operating Temperatures

- The loggers can be used in the temperature range between  $-35^{\circ}$  and  $+55^{\circ}\text{C}$ . However, it becomes increasingly difficult to read the display when the temperature falls below  $-20^{\circ}\text{C}$ .
- Battery self-discharging increases at temperatures exceeding  $45^{\circ}\text{C}$  and continuous operation at temperatures above  $45^{\circ}\text{C}$  can reduce the serviceable life by approx. 1/3.
- Lithium battery passivation, due to long-term use at temperatures above  $40^{\circ}\text{C}$ , can result in temporary read problems (self-discharge protection). This can be rectified by repeated evaluation.
- Long-term use at low temperatures down to  $-40^{\circ}\text{C}$  does not present any problems.
- We can not guarantee that the logger will always function properly if it is implemented at temperatures below  $-40^{\circ}\text{C}$ . Experience has shown that the battery freezes at approx.  $-50^{\circ}\text{C}$ , that it is no longer possible to perform measurements and that the timer tracking function can be temporarily interrupted. To make further operation possible, the logger must be reprogrammed when room temperature is reestablished.
- Temperatures exceeding  $55^{\circ}\text{C}$  can result in permanent discoloration of the display.
- Temperatures exceeding  $70^{\circ}\text{C}$  can result in deformation of the housing.
- A gas explosion can occur at the lithium battery if temperatures exceeding  $100^{\circ}\text{C}$  are reached.

### 4.3 Exceptional Environmental Conditions

Pay attention to the following when loggers are used under exceptional environmental conditions:

- UV rays diminish the stability of the housing
- IR radiation (warmth) and superheated steam can result in deformation of the housing
- There is a risk that the battery may explode if the logger is used in conjunction with microwaves

### 4.4 Maintenance

To ensure proper functioning of the logger the following steps should be part of a periodical maintenance plan:

- Calibration test in accordance with the specifications for the implemented sensors. Refer to ECOLOG data sheet D-EZ-2001E for information about the used NTC temperature sensors
- Readout of the data logger and saving the file; check of the alarm function if used
- Replace spent batteries

### 4.5 Technical Alterations

In the interest of our customers, we reserve the right to perform alterations resulting from subsequent technical developments without any particular notice. For this reason, diagrams, descriptions and the information concerning the scope of delivery are not binding.

- This product must be certified with CE



- The manufacturer guarantees that this product complies with the relevant recommendations:  
EN 50081-2 : 1992 and EN 50082-2 : 1992

## 5. Settings in elproLOG

### 5.1 Datalogger Setup

#### 5.1.1 General Settings and Channel S1 and S2, Temperature Measurements with NTC

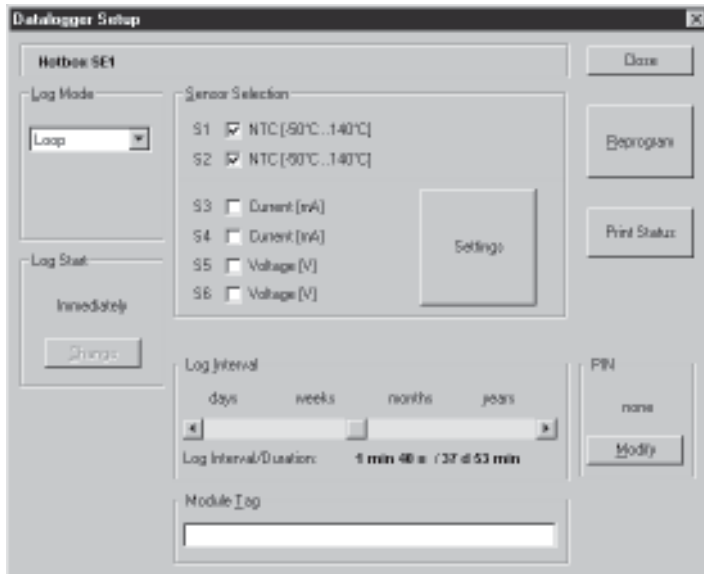

Window „Datalogger Setup“ is used to define the used measuring channels.

Refer to Chapter 5.8.1 in the elproLOG manual for detailed information about the following:

- Log Mode
- Log Start
- Log interval
- Module Tag
- Close, Reprogram, Print Status
- PIN

**Sensor Selection** Use these fields to select the measuring channels you wish to log. You can select a maximum of 4 channels from the available 6 channels.

#### - NTC [-50°C ..140°C]

Channels S1 and S2: 2 temperature measurements with NTC sensors. You can use any of the sensors obtainable from ELPRO-BUCHS. You are not required to make any other entries to define the temperature measurement procedure.

As unit for the temperature measurement the unit used by the software elproLOG is used.

#### - Current [mA]

Channels S3 and S4: 2 current measuring channels for 0/4-20mA signals.

#### - Voltage [V]

Channels S5 and S6: 2 measuring channels for measuring d.c voltage signals.

#### - Settings

Opens the window which you can use to scale the settings for current and voltage measurements.

广州虹科电子科技有限公司 广州市五山华南理工大学国家科技园 2 号楼 504-505 室 ( 510640 )

电话 : 020-3874 3030; 3874 3032 e-mail: [sales@hkaco.com](mailto:sales@hkaco.com) 网站: [www.hkaco.com](http://www.hkaco.com)

## 5.1.2 Channels S3 and S4: 0/4 - 20mA Signals

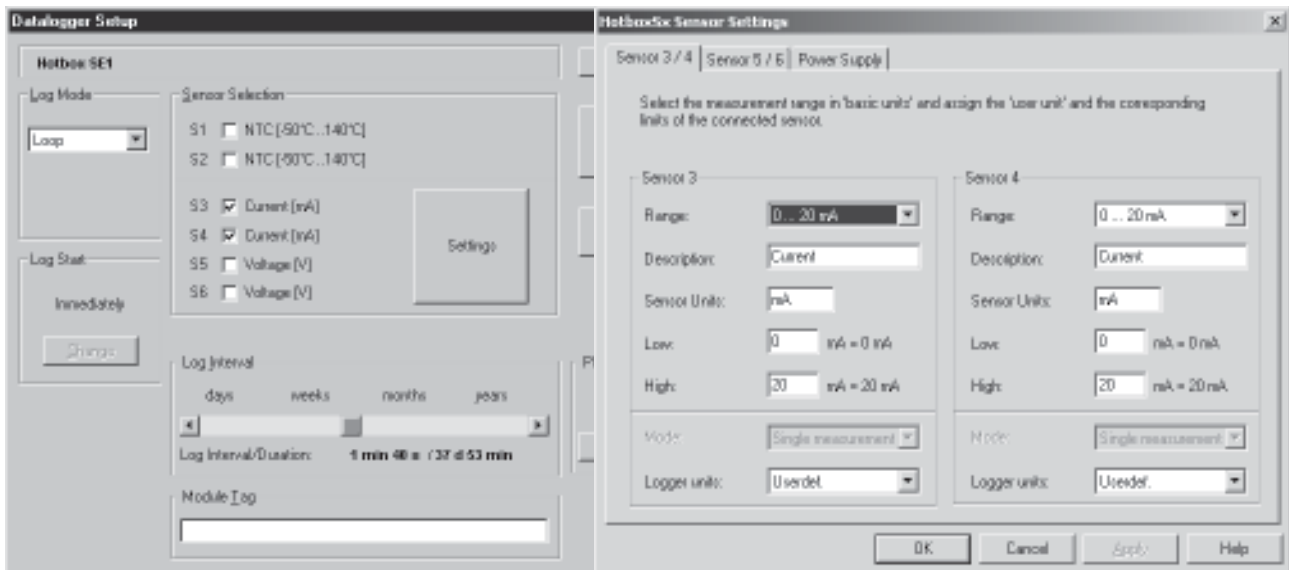

### Selection

<b>Range</b>	Selection window for measurement ranges:	0... 20mA or 4... 20mA
<b>Description</b>	Entry field for required unit of measurement.	
<b>Sensor Units</b>	Entry only possible if Logger Unit - Userdef. is selected.	
<b>Low</b>	Scaling of measurement in accordance with sensor definition for <b>lowest</b> measurement range limit.	
<b>High</b>	Scaling of measurement in accordance with sensor definition for <b>highest</b> measurement range limit.	
<b>Mode</b>	Not active for this measurement procedure	
<b>Logger units</b>	<ul style="list-style-type: none"> <li>- Temperature</li> <li>- Air humidity</li> <li>- Sensor output signal</li> <li>- Any unit of measurement (e.g. bar), can be entered in enter field „Sensor Units“</li> </ul>	<ul style="list-style-type: none"> <li>°C, °F</li> <li>%rH</li> <li>Sensor signal mA</li> <li>Userdef.</li> </ul>

**Note** The units of measurement (°C, °F and %rH) are shown at the datalogger display. For all other units of measurement, select: Logger units - Userdef. The appropriate label for the required unit of measurement can be mounted beside the display with user-labeled clips for channels S3 - S6.

### 5.1.3 Channels S5 and S6, mV/V Signals

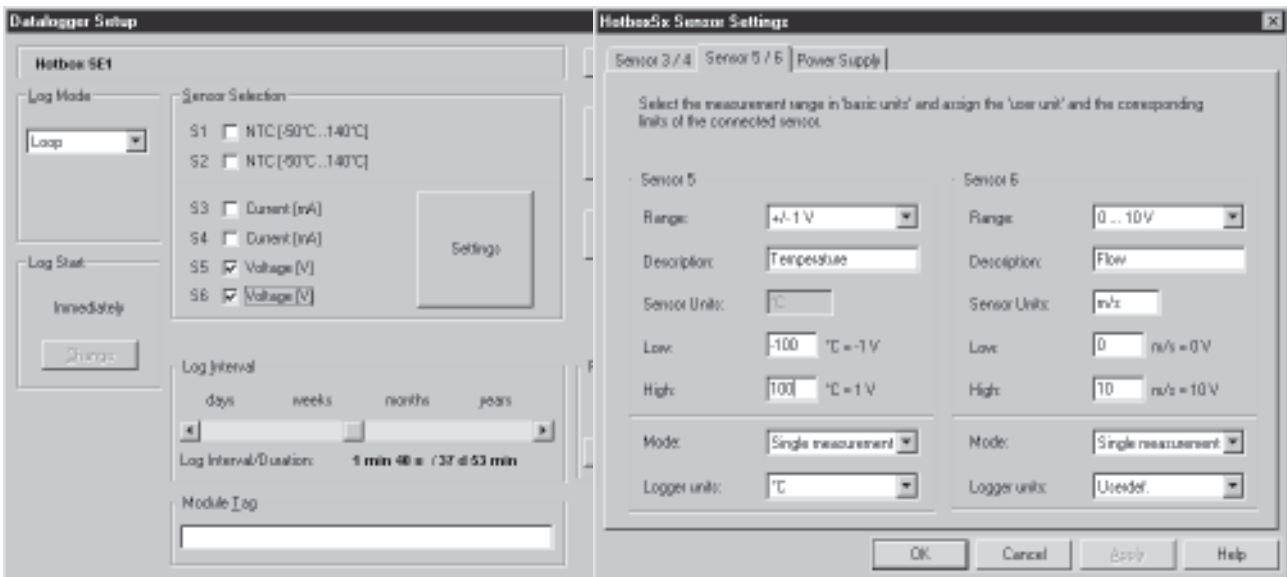

#### Selection

<b>Range</b>	Selection window for measurement ranges:	see chapter 9
<b>Description</b>	Entry field for required unit of measurement.	
<b>Sensor Units</b>	Entry only possible if Logger units - Userdef. is selected.	
<b>Low</b>	Scaling of measurement in accordance with sensor definition for <b>lowest</b> measurement range limit.	
<b>High</b>	Scaling of measurement in accordance with sensor definition for <b>highest</b> measurement range limit.	
<b>Mode</b>	- Power-save mode - Suppression of disturbance from mains frequency	Single measurement Mean value 50Hz Mean value 60Hz
<b>Logger units</b>	- Temperature - Air humidity - Sensor output signal - Any unit of measurement (e.g. bar), can be entered in enter field „Sensor Units“.	°C, °F %rH Sensor signal mV / V Userdef.

**Note** The units of measurement (°C, °F and %rH) are shown at the datalogger display. For all other units of measurement, select: Logger units - Userdef. The appropriate label for the required unit of measurement can be mounted beside the display with user-labeled clips for channels S3 - S6.





## 5.2 Extended Setup

With this function an alarm message may be resetted

See chapter 2.2

Printer selection and size definition of the short log report

See chapter 3

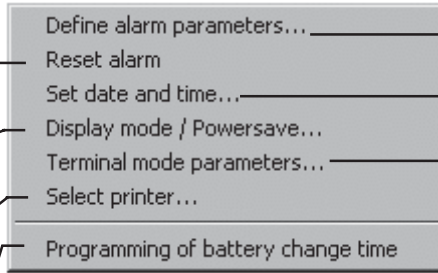

See chapter 6

To adjust the internal HOTBOX SE clock

**Terminal mode** can be used for communication between a HOTBOX SE and various terminal programs such as Hyperterminal. Further applications include integration of the HOTBOX SE in a LabView environment and data transmission to a PLC (Programmable Logic Control). Please request our documentation (D-HC6001B) if you require further information

### 5.2.1 Printing Function: Short Log Report

HOTBOX SE dataloggers can print a short log report (up to 250 values).

The scope of the log is defined with the elproLOG Software - Extended Setup - Select printer.

Printing is activated when the connected printer is switched on.

```
Ambient Temperatur Recording
S/N 1234 / 10"
SI:
°C
22.08.02 14:16 26.2
22.08.02 14:15 29.1 *
22.08.02 14:15 35.1 *
22.08.02 14:15 34.8 *
22.08.02 14:15 33.4 *
22.08.02 14:15 34.9 *
22.08.02 14:15 29.8 *
22.08.02 14:14 24.0
```

#### Legend to Index at Line End

\* = Alarm

a = Input D1

b = Input D2

c = Input D1 + D2

A = Alarm and input D1

B = Alarm and input D2

C = Alarm and input D1 + D2

广州虹科电子科技有限公司 广州市五山华南理工大学国家科技园 2 号楼 504-505 室 ( 510640 )

电话 : 020-3874 3030; 3874 3032 e-mail: [sales@hkaco.com](mailto:sales@hkaco.com) 网站: [www.hkaco.com](http://www.hkaco.com)

## 6. Definition of Alarm Parameters

The HOTBOX SE has an alarm indication feature and is equipped with an alarm contact. The alarm parameters are defined in the „Alarm Settings“ window.

### - Alarm indication

The alarm indication is independent of the sensor number, but all sensors that may cause an alarm have to be selected in the measurement function. The alarm indication has to be reset manually. It is possible to reset the alarm indication via the PC software, the keyboard or the alarm reset connector.

### - Alarm contact

In case of an alarm indication, the alarm contact is closed. The alarm contact is independent of the sensor number (collective alarm), but all sensors that may cause an alarm have to be selected in the measurement function.

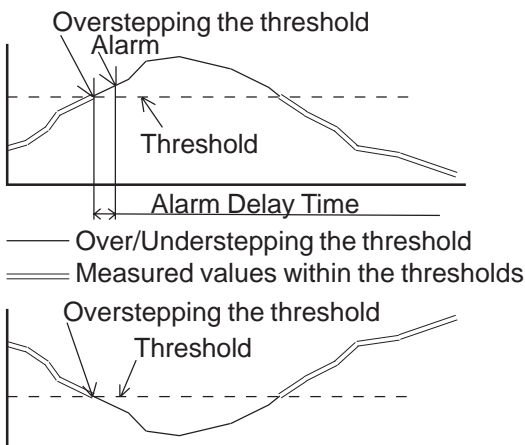

Alarm Settings

Define the upper and lower alarm thresholds for the temperature sensors and the delay time.

Alarm on

Alarm Delay Time

normal:  min

self-sustaining

controlled by D1

Time:  min

Alarm Thresholds

	Lower:	Upper:
NTC (50°C - 140°C)	<input type="text" value="-90"/> °C	<input type="text" value="140"/> °C
NTC (50°C - 140°C)	<input type="text" value="-90"/> °C	<input type="text" value="140"/> °C
Current (mA)	<input type="text" value="0"/> mA	<input type="text" value="30"/> mA
Current (mA)	<input type="text" value="0"/> mA	<input type="text" value="30"/> mA
Voltage (V)	<input type="text" value="0"/> V	<input type="text" value="1"/> V
Voltage (V)	<input type="text" value="0"/> V	<input type="text" value="1"/> V

### Alarm on

Activating this check box switches on the alarm function.

### Alarm Thresholds

Data entry field for lower and upper threshold values.

### Alarm Delay Time

#### - normal

To close the alarm contact, a measured value must overstep/understep the threshold limit for longer than the delay time defined in the "normal" data entry field.

#### - self-sustaining

This mode is used for all applications which use the alarm contact to control any external devices such as a flashlight or a telephone dialling unit. The alarm contact remains closed **until it is reset manually**. The alarm contact only remains closed during the threshold understep/overstep period if the „self-sustaining“ check box is not activated.

#### - controlled by D1

If the "controlled by D1" function is selected and contact D1 is closed, a measured value must overstep/understep the threshold limit for longer than the delay time defined in the "normal" data entry field.

### Close / Print Status

These buttons are used to printout the current status of the logger and to close the „Setup of Alarm Parameters“ window.



**The alarm function is not available in power-save mode!**

## 7. Applications

### 7.1 Temperature Measurements with NTC -50..+140°C - Channels S1 and S2

#### Material list

	Part No.
Sensor	all types 30xx-Lyy
Connector	2540-P4
Assembly#	2540-B



#### Diagram

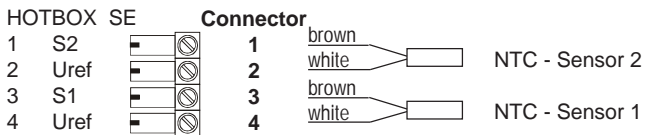

#### Settings

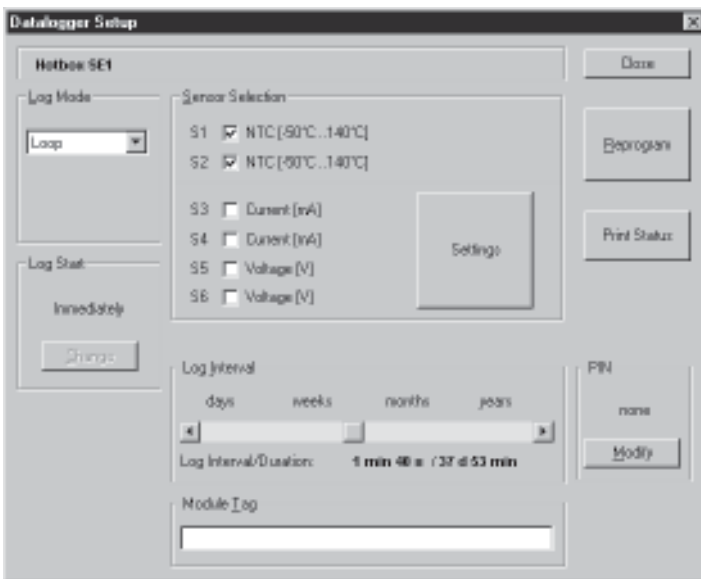

**Accuracy of measurement:** see chapter 9

# Connector assembly 2540-Px for 1 or 2 sensors including test

## 7.2 Pressure Measurement -1..24bar - Channels S3 and S4



### Material list

	Part No.
Sensor	3280-B
Connector	2540-P5
Assembly#	2540-B

### Probe connector

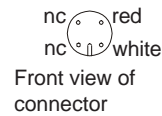

### Diagram

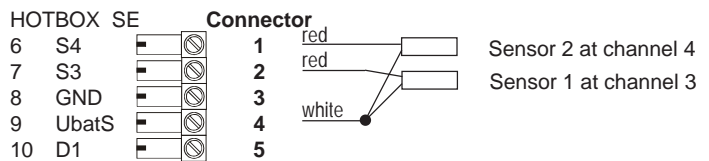

### Settings

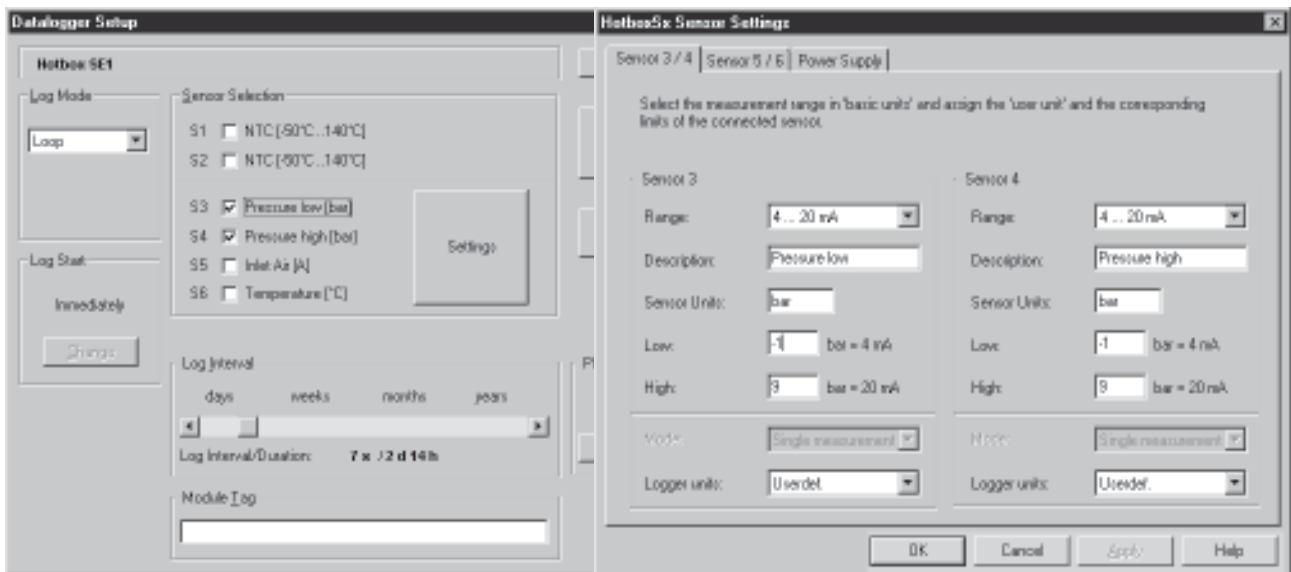

**Sensor supply** 20ms

**Serviceable life** a) Operation with display approx. 24 days  
b) Power-save mode >2 years

**Default values**

- 1 sensor; 5min recording interval; display updated every 4s
- Sensor supplied by the internal 9V alkali batteries
- Sensor permanently connected to datalogger (produces approx. 525'000 measurements)

# Connector assembly 2540-Px for 1 or 2 sensors including test

### 7.3 Flow Measurement 0.3..20m/s - Channel S3

#### Material list

	Part No.
Sensor	3264-D
Connector	2540-P5
Assembly#	2540-B



#### Diagram

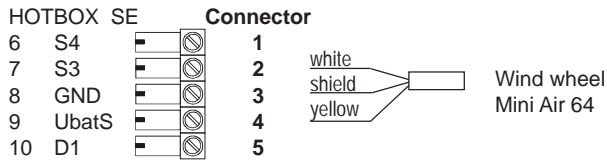

#### Settings

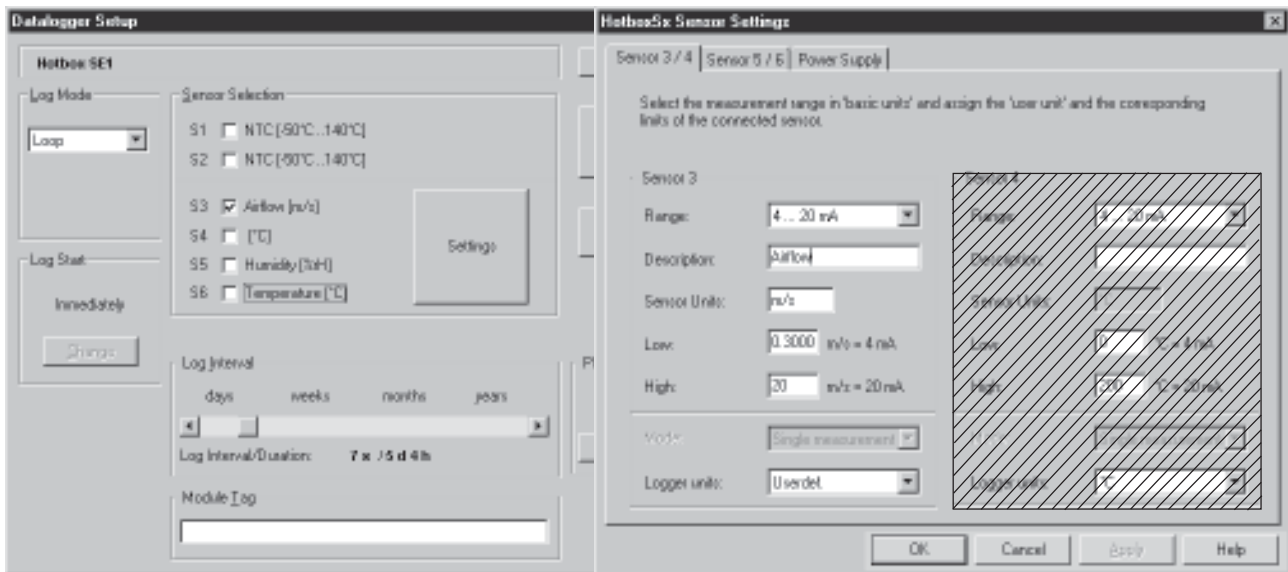

**Sensor supply** 1s

**Serviceable life** a) Operation with display approx. 64h  
 b) Power-save mode approx. 40 days

**Default values**

- 1 sensor; 1min recording interval; display updated every 4s
- Sensor supplied by the internal 9V alkali batteries
- Sensor permanently connected to datalogger (produces approx. 60'000 measurements)

# Connector assembly 2540-Px for 1 or 2 sensors including test

## 7.4 Temperature and Humidity with HygroClip - Channels S5 and S6



### Material list

Sensor	Part No.
1m cable with connector	3088-A 3216-L01

### Diagram

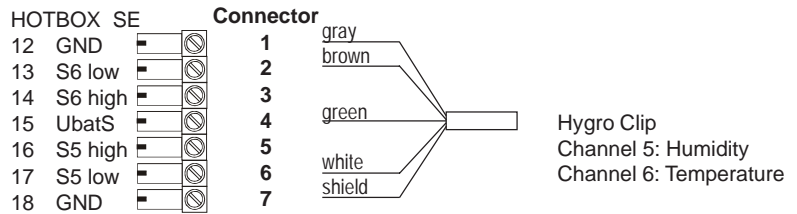

## Settings

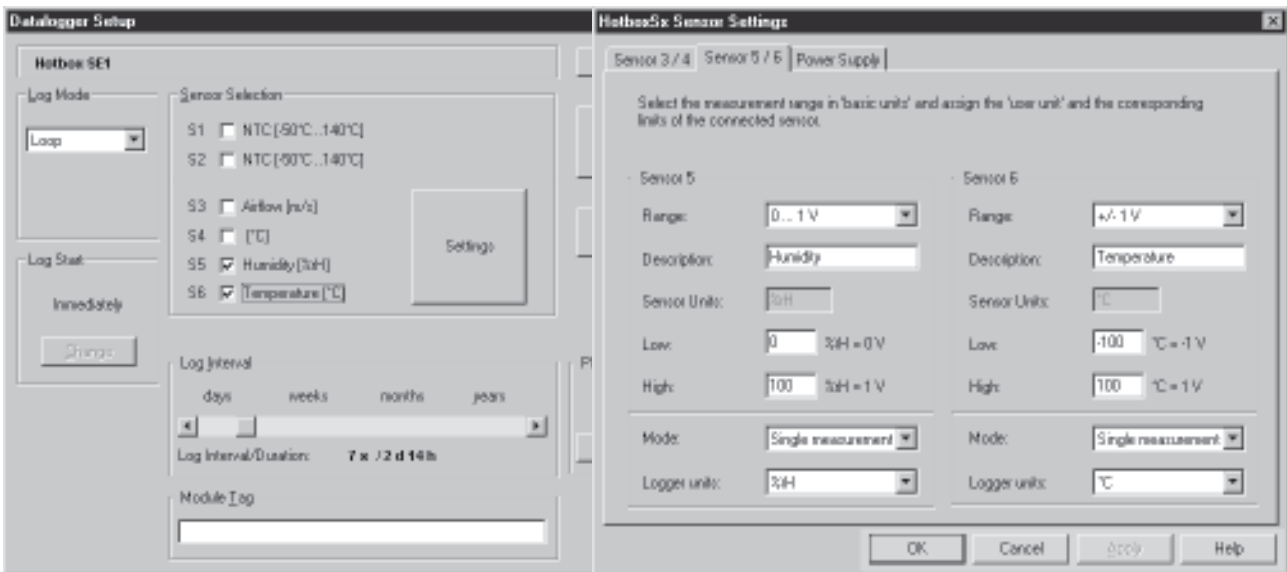

**Sensor supply** 5s

**Serviceable life** a) Operation with display approx. 2 days  
b) Power-save mode >2 years

**Default values**

- 1 sensor; 15min recording interval; display updated every 4s
- Sensor supplied by the internal 9V alkali batteries
- Sensor permanently connected to datalogger (produces approx. 82'000 measurements)

**Note** This sensor has to be sent back to the manufacturer for adjustment!

## 7.5 Current Measurement with Clip-on Ammeter 1..150A - Channel S5

### Material list

	Part No.
Sensor	3268
Connector	2540-P7
Assembly#	2540-B



### Diagram

HOTBOX SE	Connector		
12 GND		1	
13 S6 low		2	
14 S6 high		3	
15 UbatS		4	
16 S5 high		5	brown
17 S5 low		6	white
18 GND		7	

### Settings

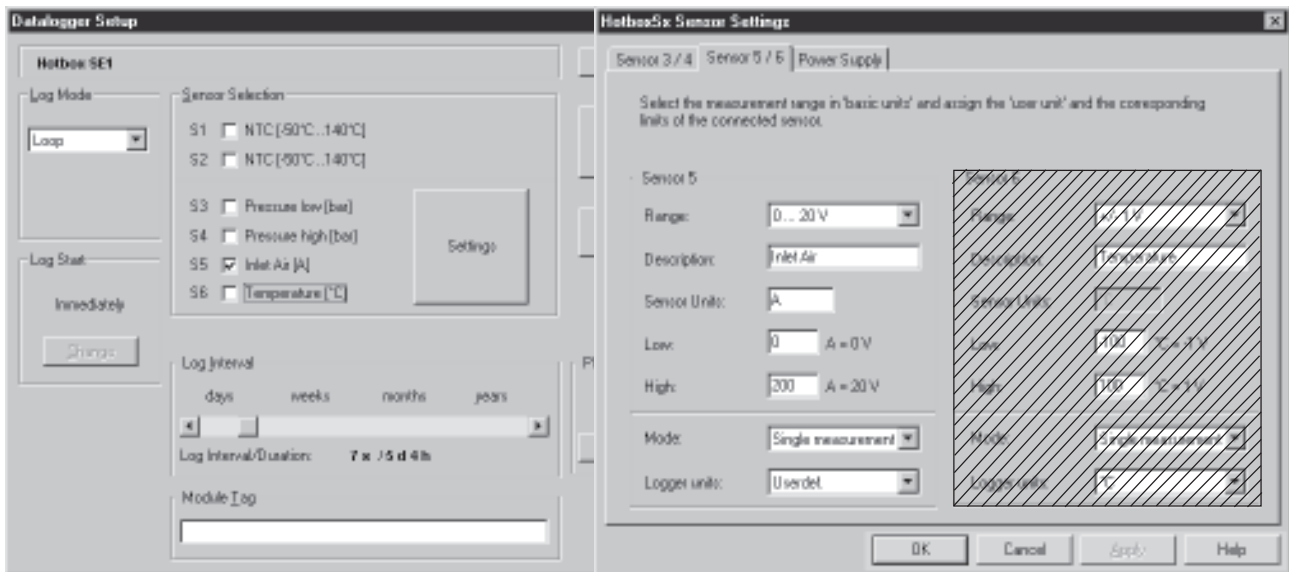

**Sensor supply** none

**Accuracy of measurement** 10% +/-1digit

# Connector assembly 2540-Px for 1 or 2 sensors including test



## 8. Pin Assignment and Connection Diagram

Wire the DB15 connector for the HOTBOX SE as shown below:

**DB15 connector**

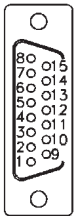

8	GND	15	RXD
7	TXD	14	Busy
6	GND	13	D1
5	GND	12	DispOn
4	n.c.	11	GND
3	GND	10	D2
2	n.c.	9	Alarm
1	GND		

**Connection diagramm**

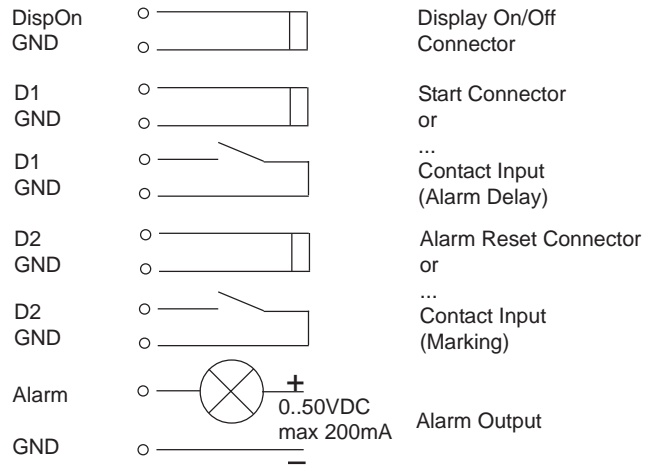

Wire the 18 pin Phoenix connector for the HOTBOX SE as shown below:

**18 Pin Phoenix**

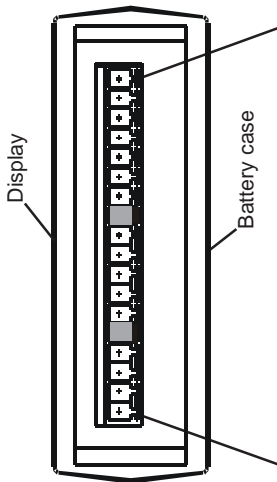

18	GND
17	S5 low [mV]
16	S5 high [V]
15	UbatS
14	S6 high [V]
13	S6 low [mV]
12	GND
11	n.c
10	D1
9	UbatS
8	GND
7	S3 [mA]
6	S4 [mA]
5	n.c
4	Uref
3	S1 - NTC
2	Uref
1	S2 - NTC

**Connection diagramm**

**Sensor supply from logger**

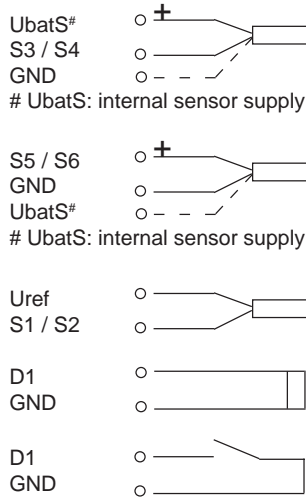

**External sensor supply**

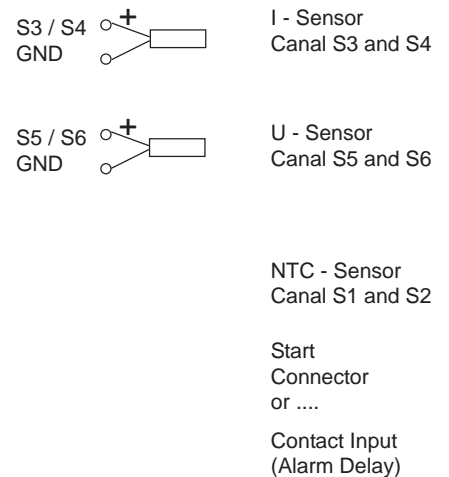

Wire the 2 pin sensor supply connector for HOTBOX SE as shown below:

**2 Pin connector**

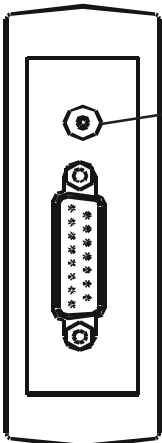

**Connection diagramm**



**Connector dimensions**

Pin Diameter: 5.5 / 2.5mm  
Length: min 12mm

Sensor supply is determined by the used sensors.  
Maximum ratings are:  
- 30VDC  
- 200mA

## 9. Measurement- Operating-Range and Accuracy

### Temperatur Measurement

with NTC (Datalogger with Sensor typical; Datalogger at room temperature)

Measurement Range	Resolution	Accuracy
-50°C.. -25°C	0.1°C	± 0.4°C
-25°C.. 0°C	0.1°C	± 0.3°C
0°C.. 70°C	0.1°C	± 0.2°C
70°C.. 100°C	0.1°C	± 0.4°C
100°C.. 140°C	0.1°C	± 0.7°C

### Voltage Measurement

Internal Resistance: low = 100kΩ; high = 2.5MΩ

Measurement Range	Resolution	Accuracy <sup>#</sup>
low		
0.. 100mV	0.1mV	0.5% +/- 5digit
0.. 200mV	0.1mV	0.5% +/- 3digit
0.. 500mV	0.1mV	0.5% +/- 3digit
0.. 1V	1mV	0.2% +/- 2digit
0.. 2V	1mV	0.2% +/- 2digit
+/- 100mV	0.1mV	0.5% +/- 5digit
+/- 200mV	0.1 / 1mV	0.5% +/- 3digit
+/- 500mV	0.1 / 1mV	0.5% +/- 3digit
+/- 1V	1 / 10mV	0.2% +/- 2digit
+/- 2V	1 / 10mV	0.2% +/- 2digit
high		
0.. 5V	1mV	0.3% +/- 3digit
0.. 10V	10mV	0.2% +/- 3digit
0.. 20V	10mV	0.3% +/- 3digit
+/- 5V	1 / 10mV	0.3% +/- 3digit
+/- 10V	10mV	0.2% +/- 3digit
+/- 20V	10 / 100mV	0.3% +/- 3digit

### Current Measurement

Load Resistance = 50Ω

Measurement Range	Resolution	Accuracy <sup>#</sup>
0mA.. 20mA	0.1mA	0.2% +/- 1digit
4mA.. 20mA	0.1mA	0.2% +/- 1digit

**ADC Resolution** 11bit (+sign)

**Time** Accuracy of the internal clock +/-20 minutes/year

**Operating Range** -35°C.. 55°C, Display readable down to -20°C  
0%.. 100%rH, non condensing  
IP30

# Typical values; datalogger at room temperature; related to range

## 10. Status and Error Codes

### Logger Display

Prn	Data are printed
b.F.	Battery voltage is too low
C.F.	Datalogger is faulty or massive range overflow
S.C.	Sensor has a short circuit
Err	Error during printing
L.C.	Datalogger is faulty
n.c.	No sensor is connected
O.F.	Overflow of measurement value
U.F.	Underflow of measurement value

### Logger Status in elproLOG

#### RAM IMG-BMP destroyed

This error message is visible in the logger status information, line: Module time.

The reason for such an error message might be, a battery replacement where the battery change time has not been set. (see also Chapter 3).

## 11. Commodities and Accessories

### Part.-No

2820	3,6 Volt Lithium Battery 1900mAh, set with 2 pieces, shelf life min. 5 years
.....	9 Volt Alkali Battery 400mAh, set with 10 pieces, shelf life min. 2 years Batteries with 2-3times higher capacities on request!
2832-C	Power supply unit for external sensors
3032-IS	Display-On connector
2540-EA	Start connector
3032-EA	Alarm-Reset connector
2540-CL	User-labeled clip
2540-P4	Connector with screw terminals, 4 pins, with connector housing
2540-P5	Connector with screw terminals, 5 pins, with connector housing
2540-P7	Connector with screw terminals, 7 pins, with connector housing
2540-S	Connector set consisting of one 4, 5 and 7 pin connector, with screw terminals, no connector housing
2318	Data cable PC
2319	Protocol printer Seiko DPU414
2309-F	Data cable for Seiko DPU414
Sensor	Please see corresponding documentation

**广州虹科电子科技有限公司** 广州市五山华南理工大学国家科技园 2 号楼 504-505 室 ( 510640 )

电话 : 020-3874 3030; 3874 3032 e-mail: [sales@hkaco.com](mailto:sales@hkaco.com) 网站: [www.hkaco.com](http://www.hkaco.com)

## 12. Dimensional Drawing

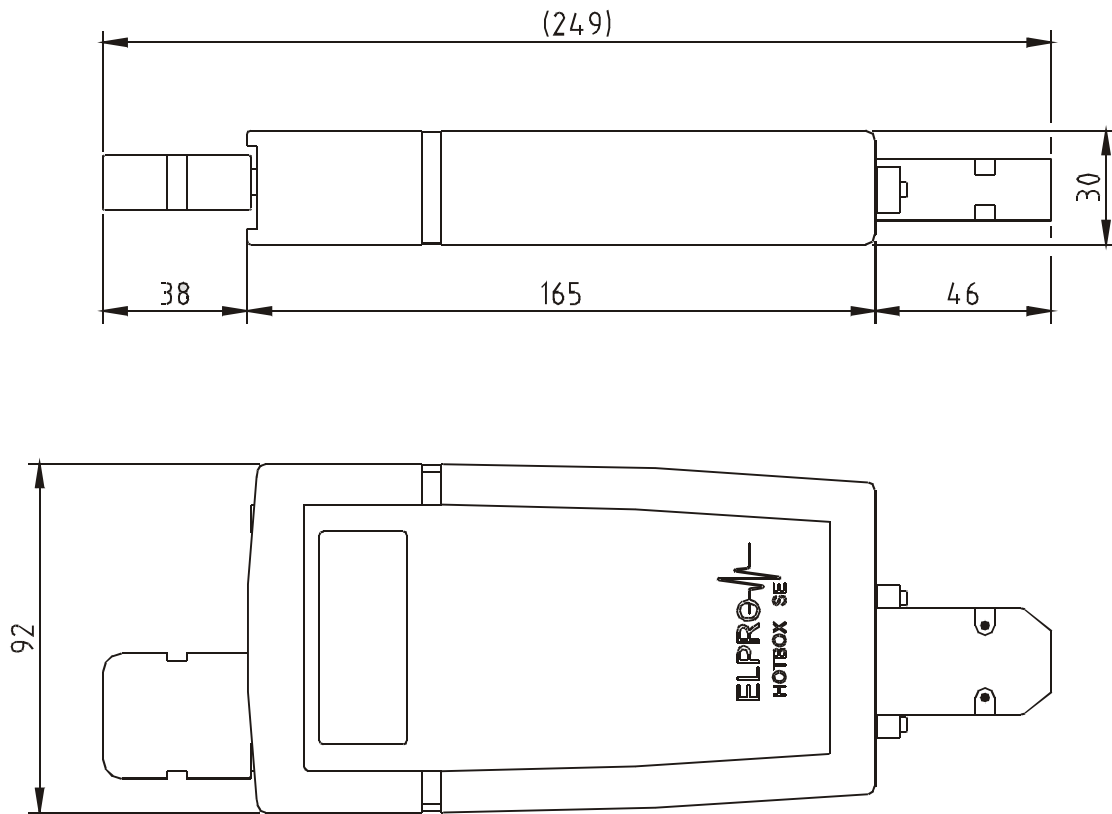

Your Distributor:

ELPRO-BUCHS AG  
9471 Buchs SG  
Switzerland



[www.elpro.com](http://www.elpro.com)

广州虹科电子科技有限公司 广州市五山华南理工大学国家科技园 2 号楼 504-505 室 ( 510640 )

电话 : 020-3874 3030; 3874 3032 e-mail: [sales@hkaco.com](mailto:sales@hkaco.com) 网站: [www.hkaco.com](http://www.hkaco.com)